

SEAT SERIES

SEAT 35

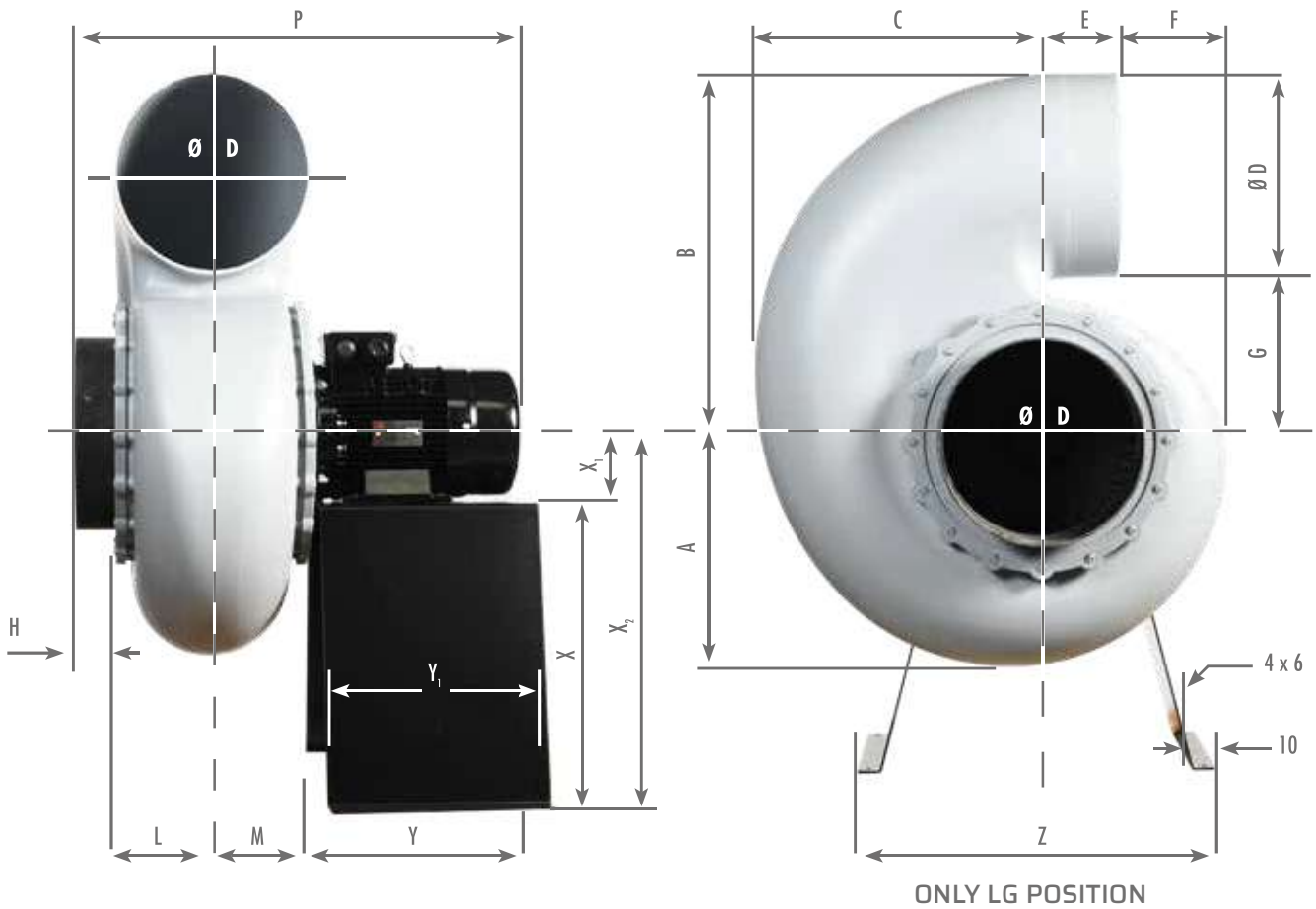

! The roof kit for the SEAT 35 is black, not pink as shown in the "accessories" category.
The pink roof kit applies to SEAT 15, 20, 25, 30.

Available in  

Dimension (mm) - Metal stand not included (see accessories) Motor axis heights may vary according to the type of motor used																		
RPM	A	B	C	ØD	E	F	G	H	L	M	P	S	Y	Y ₁	Z	X	X ₁	X ₂
930	370	570	450	315	130	170	255	60	150	170	724	334	350	314	600	468	112	580
1450	370	570	450	315	130	170	255	60	150	170	792	402	350	314	600	468	112	580
1450 ATEX or 7,5 kW	370	570	450	315	130	170	255	60	150	170	822	432	350	314	600	468	132	600

Left Rotation (Counter-Clockwise)



NOISE LEVELS

Acoustic (dB)					Frequency Octave (Hz)							
Speed (T/min)	Qv (m ³ /h)	Sp (Pa)	LwA dB(A)	LpA* dB(A)	63	125	250	500	1000	2000	4000	8000
930	3770	290	79	59	86	88	79	76	73	71	68	62
1450	5880	704	89	69	96	98	89	85	82	81	77	71

*Acoustic pressure Lp at 3 meters - Outlet acoustic data available on request.

SEAT SERIES - SEAT 35

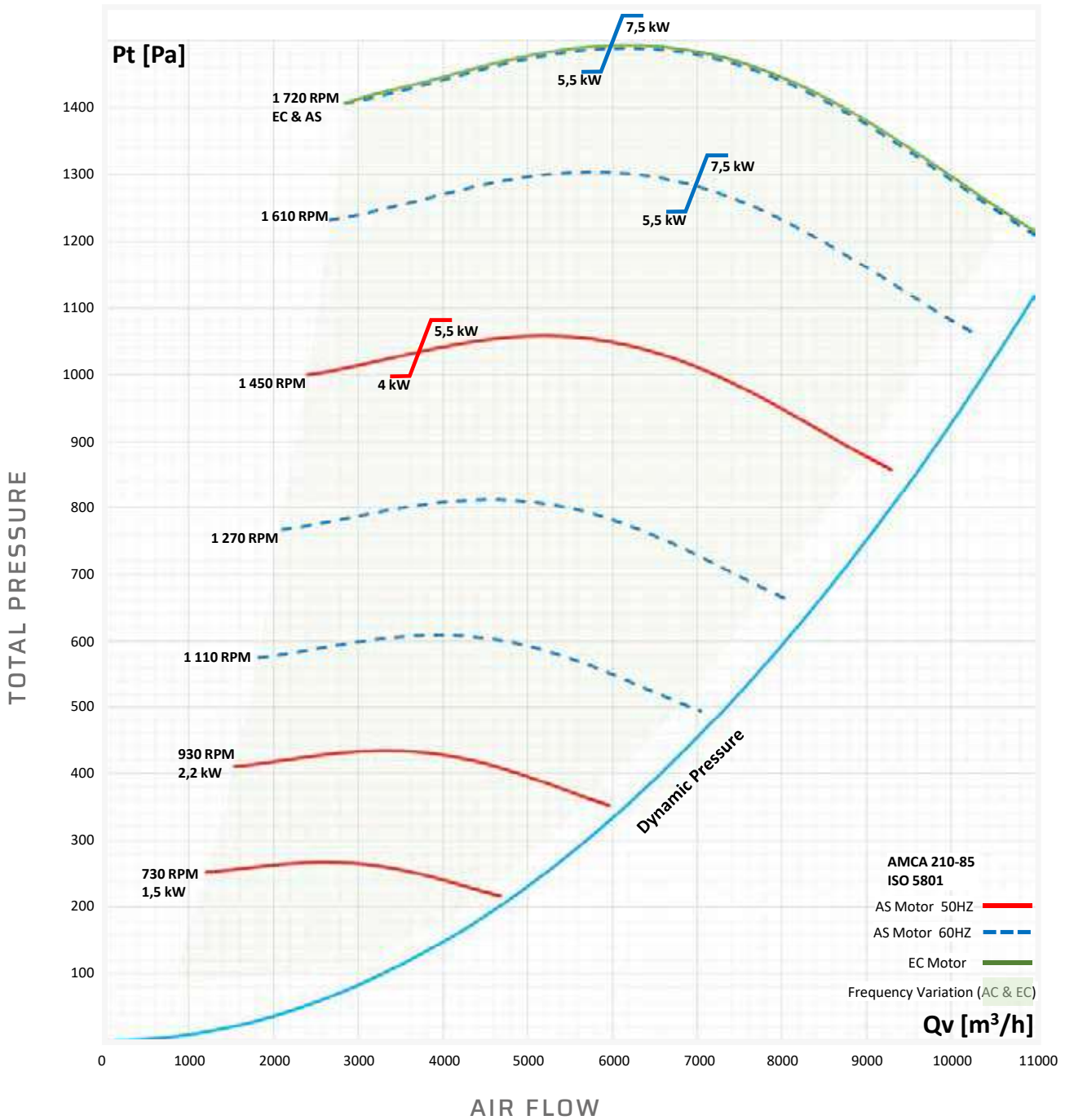

ELECTRICAL FEATURES

Motor	Power (kW)	Motor RPM	Voltage (V)	Intensity (A)	Weight (kg)	Reference Number
IP55 Asynchronous Three-Phase	1,5	730	230/400	7,45/4,3	37,8	51350000
	2,2	930	230/400	8,85/5,09	47,7	51351000
	4	1450	230/400	13,8/7,95	50,2	51352400
	5,5	1450	400/690	10,7/6,19	62,2	51352000
	7,5	1450	400/690	14,3/8,23	70,4	51352001
IP66 EC Three-Phase	4	1720	360/460	17,2	53	52352000
IP66 Asynchronous Three-Phase ATEX 	2,2	930	230/400	9,7/5,6	45,1	51351003
	5,5	1450	400/690	11,5/6,6	66,6	51352003
	7,5	1450	400/690	15/8,68	70,2	51352004

Mandatory PTC Sensor for ATEX motor with Frequency Inverter.